

# Drum Scrubber (DS)



## Economical, Durable Deep Bed Design

### SPECIFICATIONS:

Applications	Wastewater odor removal
Airflow Range	0 CMH (0 CFM) – 1,700 CMH (1,000 CFM) <i>*Please review the model selection table for more information</i>
Configuration	Vertical airflow
Construction Material	<b>Standard:</b> High-density polyethylene (HDPE) <b>Other options:</b> Stainless Steel, Fiberglass reinforced plastic
Particulate Filtration	<b>Odor Control Applications:</b> Mist and Grease Filter <b>Other Applications:</b> 5 cm (2 in), 30% MERV 8 Prefilter, 15 cm (6 in), 95% MERV 13 Final Filter <i>*Other filter sizes/options available</i>
Blower Configuration	<b>DRAWTHRU: Standard Design:</b> Enables the blower to operate in clean air, increasing its lifespan and reducing maintenance needs. <i>*Redundant blowers and other special options available</i>
Customizable	Multiple sizes and configurations available. Reference the model selection table for details. Add-on accessories like sound enclosures are available. <i>PureAir specializes in customization.</i>



### BENEFITS:

- **Low Maintenance:** Simple replacement and disposal of spent media.
- **Multiple Media Beds:** Offers flexibility for multiple chemisorbant media. For details, refer to the media brochure.

### MEDIA BED INDICATOR:



This unit includes a metal media bed indicator installed at an angle within the system, aligned against the airflow to monitor media life.

- **Corrosion Alert:** A dark, corroded color on the indicator signal expired media. When corrosion reaches halfway, contact PureAir to replace the media and maintain optimal system performance.
- **LIFEGARD™:** For real-time updates on media lifespan, consider the LIFEGARD™ as a system upgrade.



## MODEL SELECTION TABLE

DS MODEL #	AIR FLOW RANGE CMH (CFM)	MOTOR RANGE kW (HP)	MEDIA VOLUME M <sup>3</sup> (FT <sup>3</sup> )*	Shipping Weight KG (LBS)	Operating Weight KG (LBS)
100	85 - 170 (50 - 100)	.37 (.5)	.14 (5)	79 (175)	156 (345)
300	170 - 510 (100 - 300)	.56 (.75)	.25 (10)	120 (270)	350 (770)
500	510 - 850 (300 - 500)	1.1 (1.5)	.42 (17)	200 (440)	485 (1070)
1000	850 - 1700 (500 - 1000)	2.2 (3)	1.1 (39)	272 (600)	921 (2030)

\* Special Airflows are Available

## Notable Customers:

- Belmont County Fairgrounds
- Byrne Hollow Farms
- Coney Island WWTP
- CTI Beanmaker
- Dean Foods
- Imperial Landfill
- LOVECO
- Town of Strasburg
- Wahoo Creek Influent PS

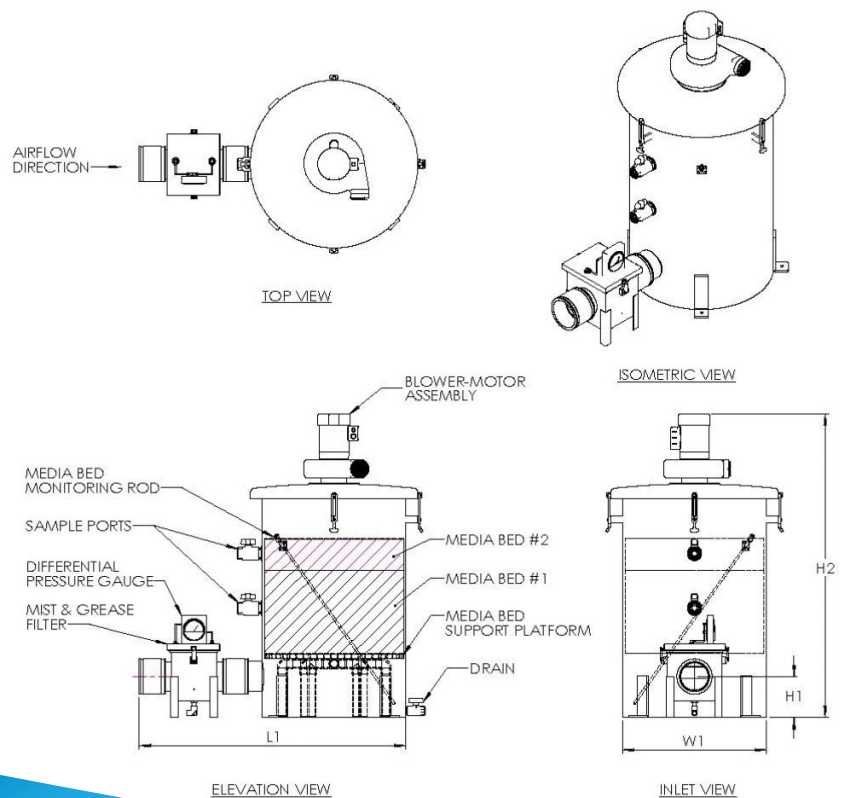

+1 678.935.1431

Toll Free: 866.543.7479

www.PureAirFiltration.com

6050 Peachtree Pkwy, Suite 240-187, Atlanta, GA, 30092 USA